

Electric Lock Installation Manual

Note: Electric lock improves the safety for your gate, and it is highly recommended if you have animals or live in areas affected by strong winds when the gate is longer than 1.5 meters (7ft).

Electric Lock Part List

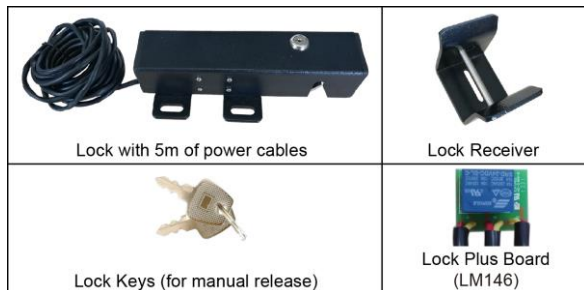

Important Information:

1. Before you install the Electric Lock please be sure the gate is level, moves freely, and does not bind or block against barriers.
2. For the Electric Lock to work correctly, the gate must close firmly engaging the lock catch against the lock receiver.
3. The Electric Lock must be installed on the outside of the gate if on the **Push-to-Open** gate.
4. Due to the various mounting conditions, mounting hardware is not provided. Read this manual carefully to determine the mounting hardware required for your condition.
5. For dual gate, the lock must be installed on the Master Gate (gate 1) which is near the Control Box, and the lock receiver must be installed on the Slave Gate (gate 2).

(If the gate near the control box has been set up as slave gate, you can change the settings following “User’s Manual” → “Control Board Settings” → “Master/Slave Gate Set”)

Installation for Single Gate

Step 1: Disengage the clutch of the opener with the Release Key. You can move the gate by hand, so the gate can swing freely during installation of the Electric Lock.

Step 2: With the gate in the closed position, determine the best location for the lock and receiver. The lock and receiver must be level and aligned with the opener. The lock and receiver should have a solid surface or tube fence to provide stability.

Step 3: For **Metallic Tube** gate, if the thickness of the fence post is bigger than or equal to 3mm, you can thread on the fence post, and fasten the lock and receiver only using bolts (without nuts). Otherwise, drill holes through out the fence post, and fasten the lock and receiver with bolts, lock washers and nuts.

Of course, you can weld them directly.

For **Chain Link** gate, you will need U-Bolts, saddles, lock washers and nuts for the lock and receiver.

Step 4: Recheck the lock’s position and alignment, make sure the electric lock work correctly.

Step 5: Connect the lock’s power cables to the control board of **swing gate opener and Lock plus board**. (See Figure E).

Note: Be sure that the clutch of the opener is engaged before you prepare to activate your opener (Use the Release Key).

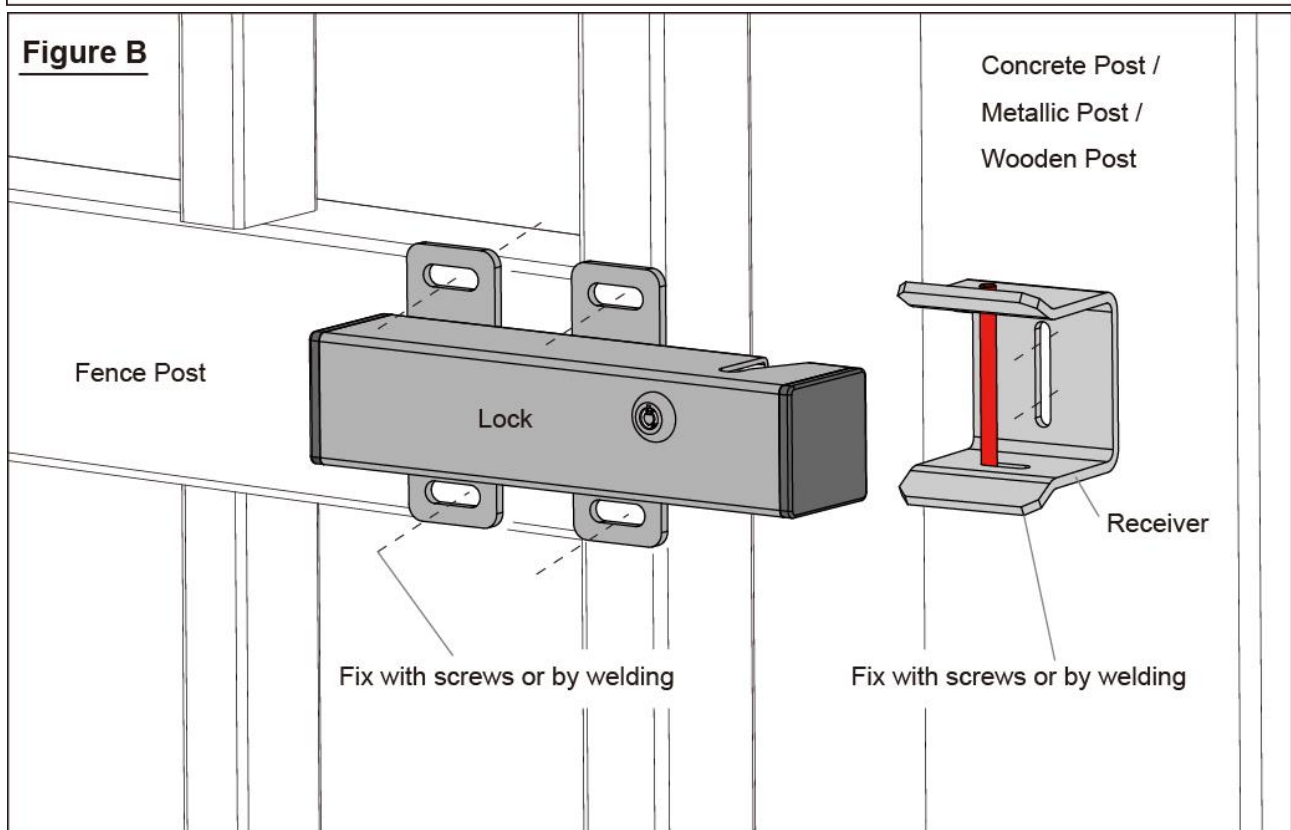
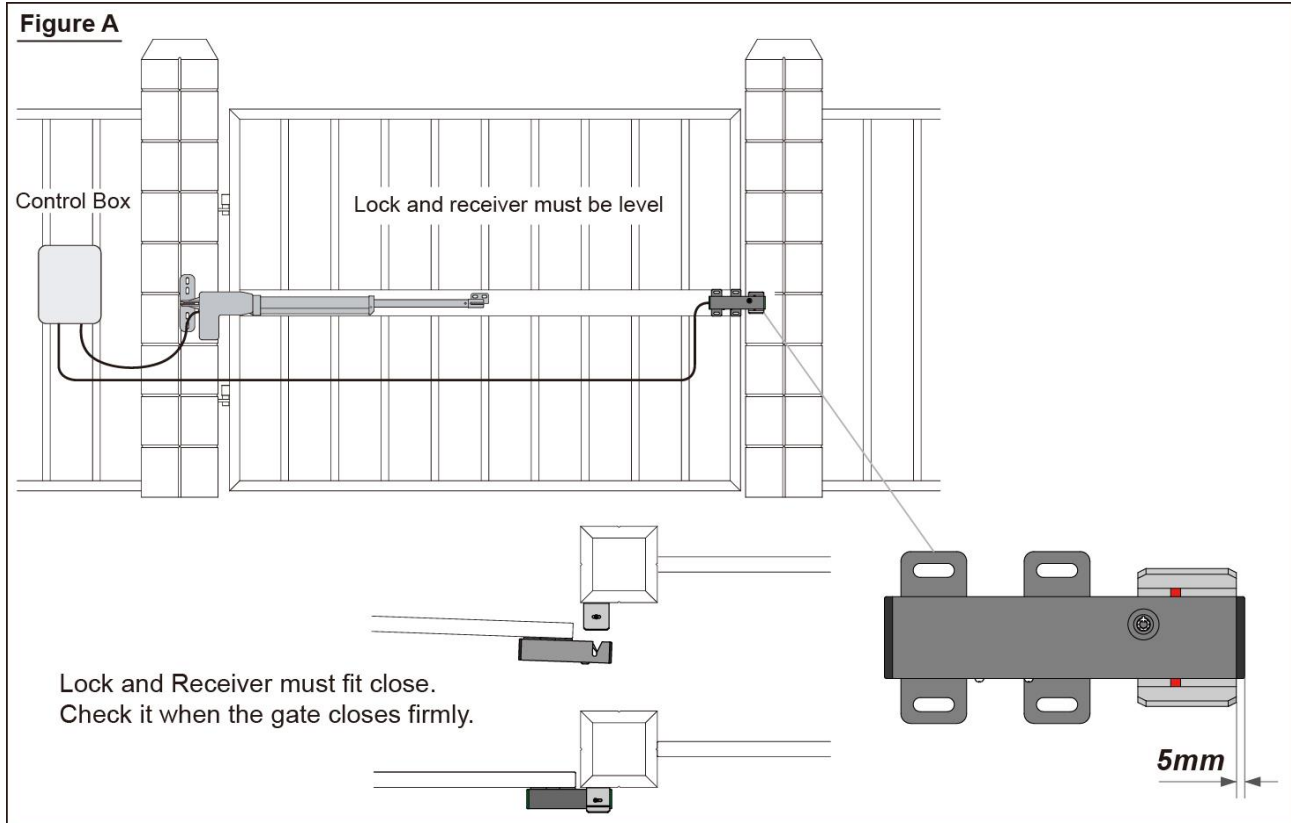

Installation for Dual Gate

Step 1: Disengage the clutches of the openers with the Release Key. You can move the gates by hand, so the gates can swing freely during installation of the Electric Lock.

Step 2: With the gates in the closed position, determine the best location for the lock and receiver. The lock and receiver must be level and aligned with the openers. The lock and receiver should have a solid surface or tube fence to provide stability.

Step 3: For **Metallic Tube** gates, if the thickness of the fence post is bigger than or equal to 3mm, you can thread

on the fence post, and fasten the lock and receiver only using bolts (without nuts). Otherwise, drill holes through out the fence post, and fasten the lock and receiver with bolts, lock washers and nuts.

Of course, you can weld them directly.

For **Chain Link** gates, you will need U-Bolts, saddles, lock washers and nuts for the lock and receiver.

Step 4: Recheck the lock's position and alignment, make sure the electric lock work correctly.

Step 5: Connect the lock's power cables to the **control board of swing gate opener and Lock plus board.**

(See Figure E).

Note: Be sure that the clutches of the openers are engaged before you prepare to activate your openers (Use the Release Key).

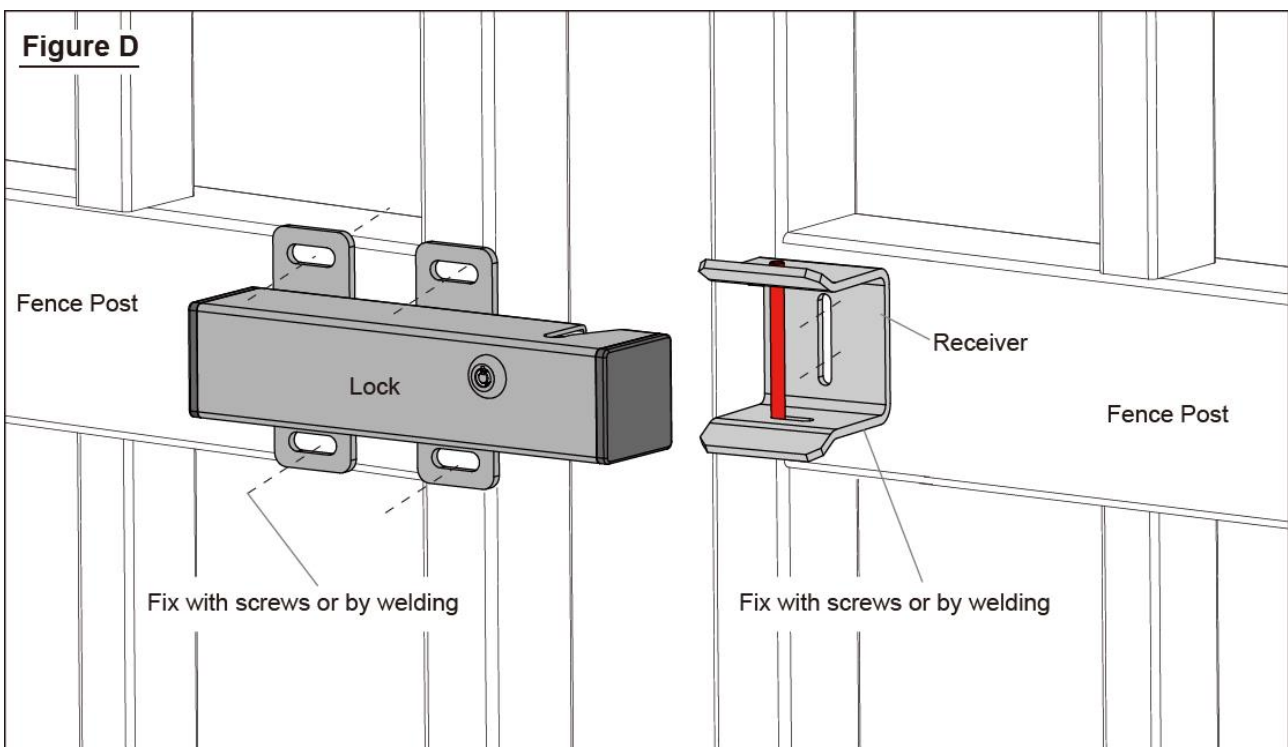
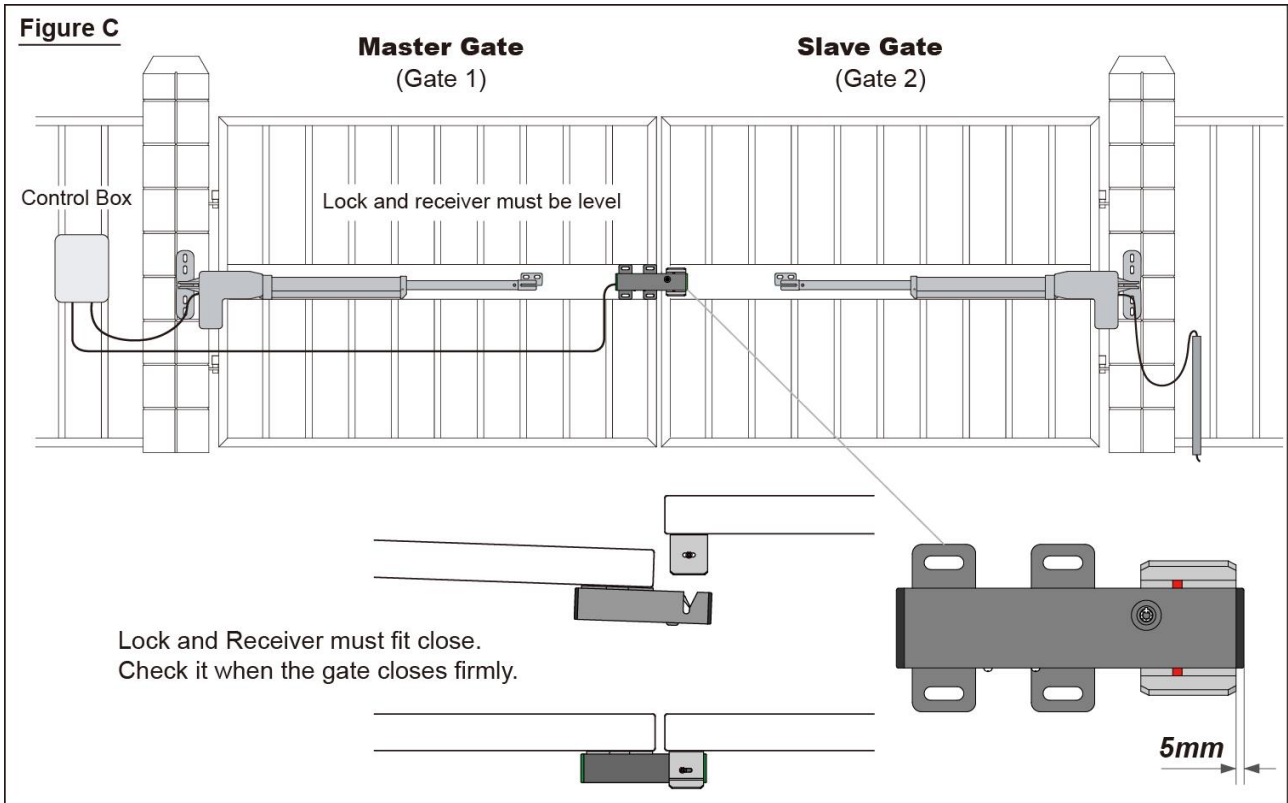

Connecting of the Lock

The electric lock has been connected with the E-plus board in factory. You can detach the plug&socket and then place the E-plus board in the control box and then re-plug the E-plus board to the electric lock. Other 2 set wires of the electric lock should be connected to the control board as the following wiring diagram and the wiring diagram in the manual of gate opener.



Figure E

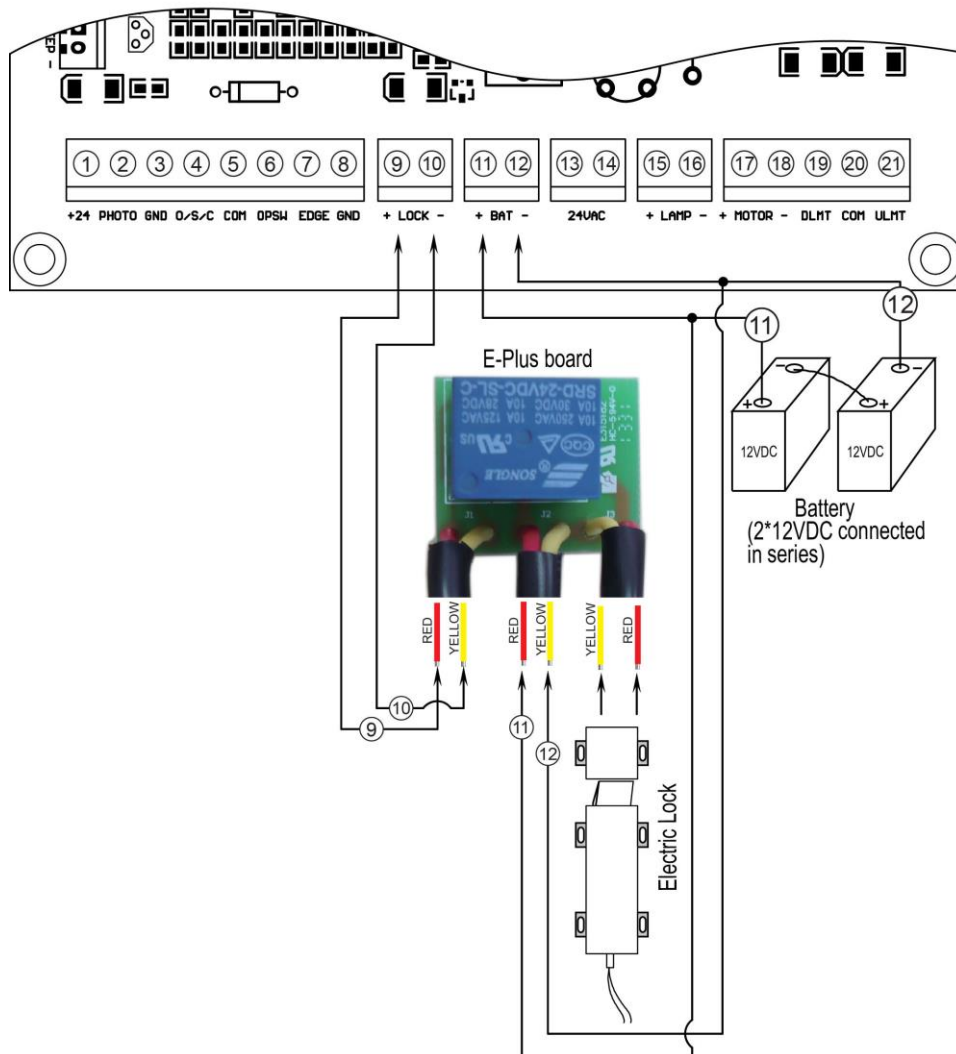

NOTE: The wiring diagram is an example of only one model gate opener. Actual wire connection please refers to the user manual of the gate opener.